

# AUDIO OUT CABLE WIRING

## Attenuator Audio Out to Xcvr cable wiring

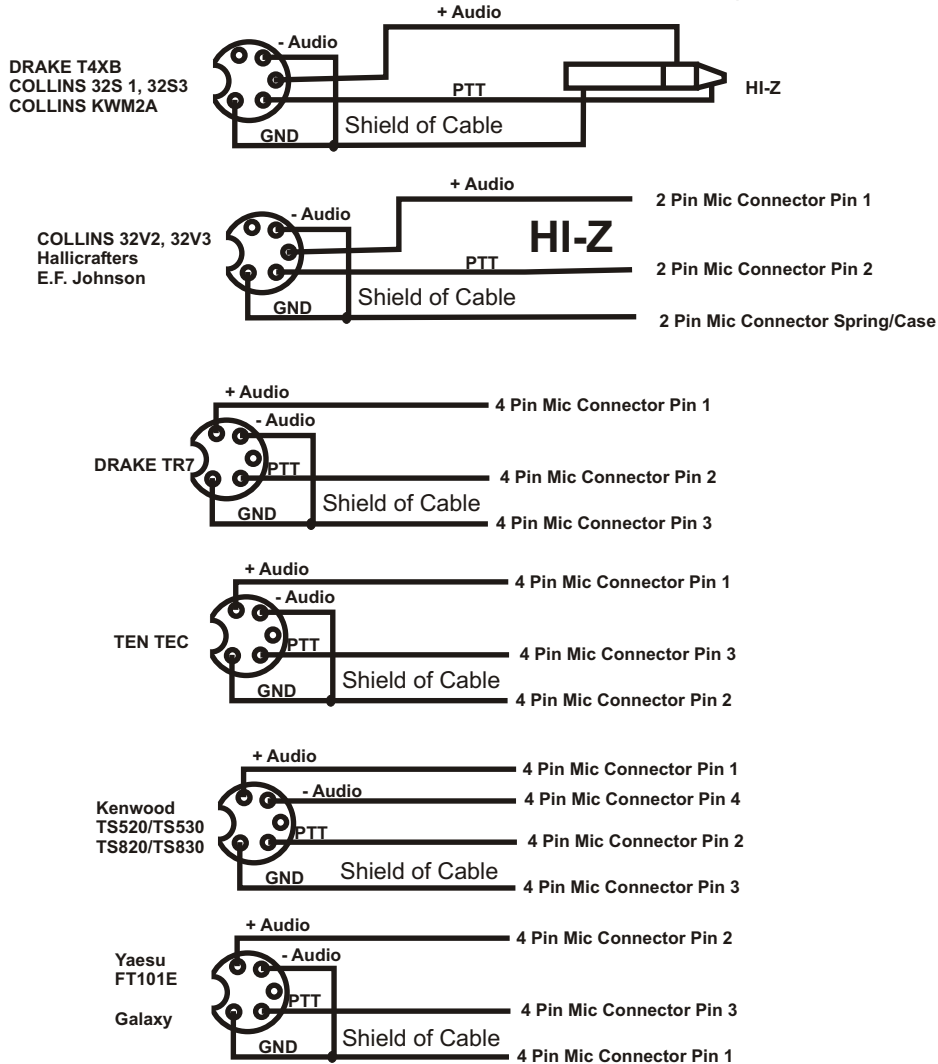

DIN connectors shown on the side to be soldered  
DO NOT SOLDER TO SHIELD OF DIN

# iBox

## VARIABLE ATTENUATOR AND INTERFACE BOX



## OPERATING MANUAL

# iBox

VARIABLE ATTENUATOR  
AND  
INTERFACE BOX

OPERATING MANUAL

April 2003



Julius D. Jones  
19 Vanessa Lane  
Staatsburg, N.Y. (12580)  
(845) 889-4253

E-mail: [Julius@W2IHY.COM](mailto:Julius@W2IHY.COM)

Home Page: [http:// www.w2ihy.com](http://www.w2ihy.com)

© 2003 W2IHY, ALL RIGHTS RESERVED

## AUDIO OUTPUT CABLE WIRING

### Attenuator Audio Out to Xcvr cable wiring

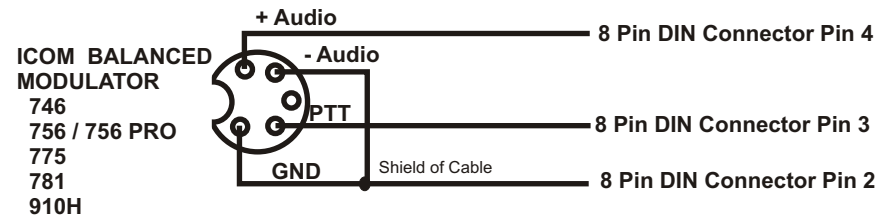
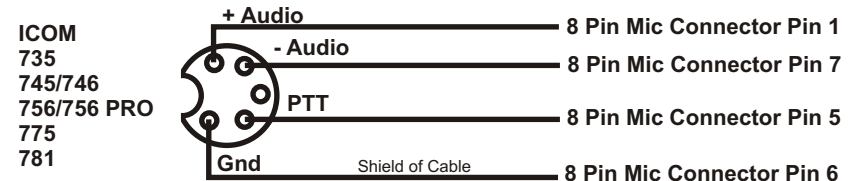
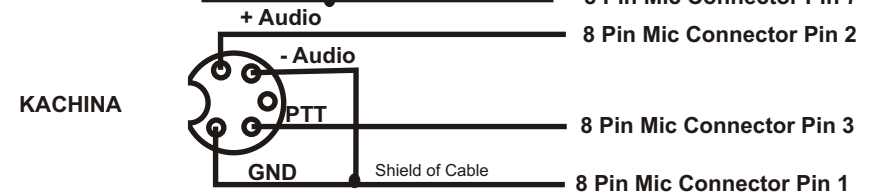
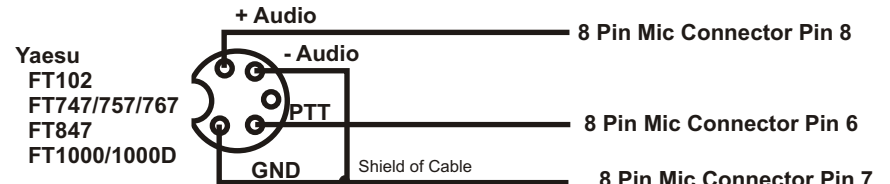
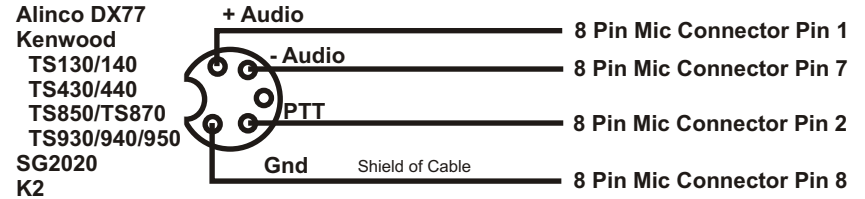
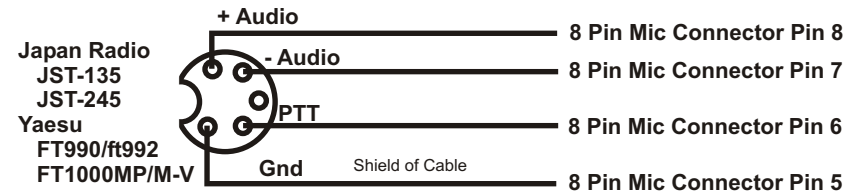

DIN connectors shown on the side to be soldered  
DO NOT SOLDER TO SHIELD OF DIN

# AUDIO OUTPUT CABLE WIRING

## Attenuator Audio Out Wiring

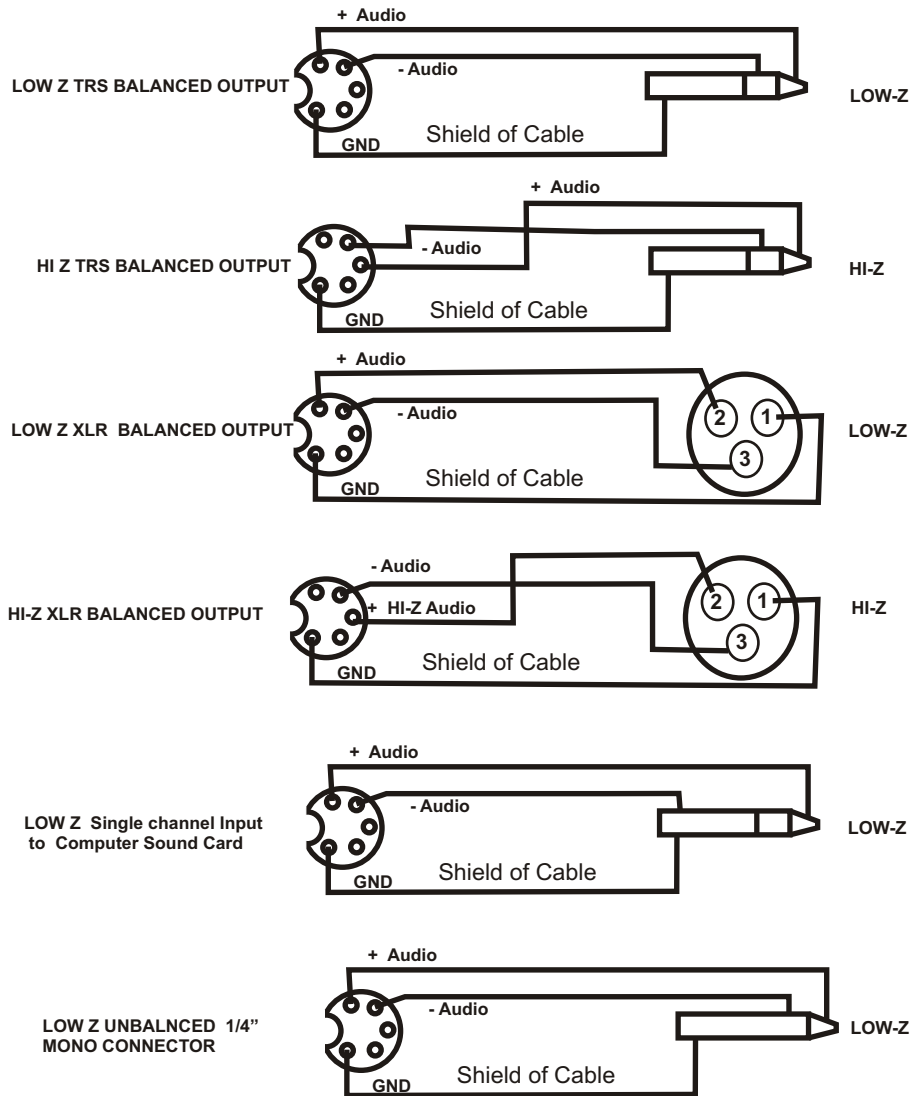

# INTRODUCTION

## iBox by W2IHY

iBox is a variable audio attenuator designed to be a versatile accessory for the serious amateur. iBox can be used to not only provide the proper audio levels and impedance matching between pieces of equipment in your audio chain or to your amateur radio equipment but it may also be used to eliminate ground loops that usually show up in the form of hum. iBox can also be used to provide RF isolation between components. iBox achieves its outstanding isolation through use of a high quality audio transformer and filter networks. iBox's input impedance is 600 ohms. The output impedance of the iBox may be selected to be either 600 ohms or 50K ohms. This means the iBox can be connected to modern and vintage radio equipment as well as between audio rack components.

iBox was designed at the request of amateurs who were using studio audio equipment and needed a more versatile way to level match, RF isolate, audio isolate, PTT control and impedance match audio and transmitting components..

We feel so confident that you will be delighted with the iBox we offer a 30 day money back , no questions asked, guarantee. The iBox represents affordable audio technology designed for amateur radio use.

# iBox CONTROLS

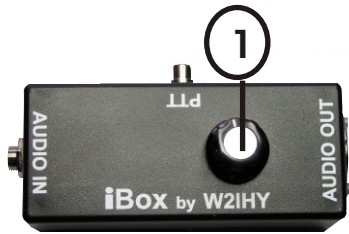

## (1) Output Level Control (R2)

This potentiometer (pot.) adjusts the audio output of the iBox. Turning the pot. fully counter-clockwise will obtain a signal at the Audio Output about 48dB less than the input signal. Turning the pot. clockwise will increase the signal level to the Audio Output.



## (2) Audio Input (J1)

This 1/4" stereo jack (also known as a Tip-Ring-Sleeve jack) is used to bring audio into the iBox.

<== Audio Plug from Source to Attenuator ==>

AUDIO CONFIGURATION	TIP	RING	Sleeve
Source: Balanced Output Wire Input Plug: Balanced Input	+ MIC	- MIC	Ground
Source: Balanced Output Wire Input Plug: Unbalanced Input	+ MIC	- MIC and Ground	- MIC and Ground
Source: Unbalance Output Wire Input Plug: Unbalanced Input	+ MIC	Ground	Ground

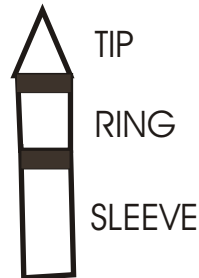

# AUDIO INPUT CABLE WIRING

## Attenuator Audio Input Wiring

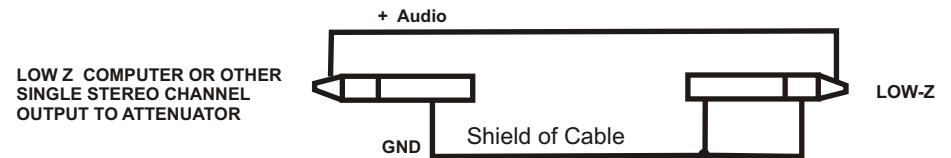
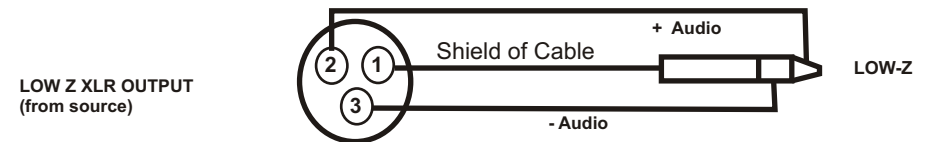
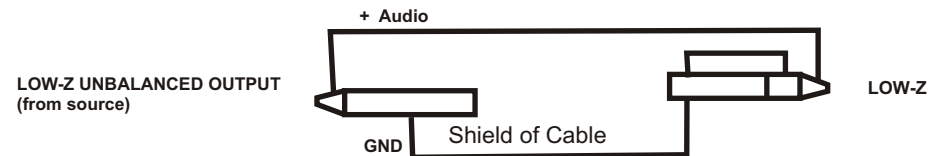
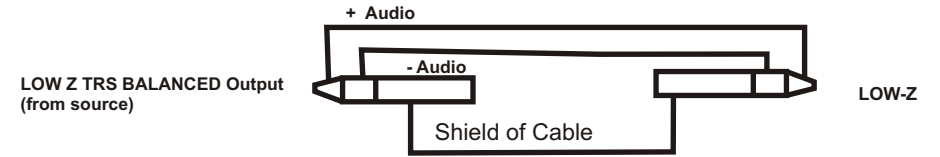

See page 8 for additional cable wiring information.

# iBox LOW-Z AUDIO OUT RESPONSE CHARACTERISTICS

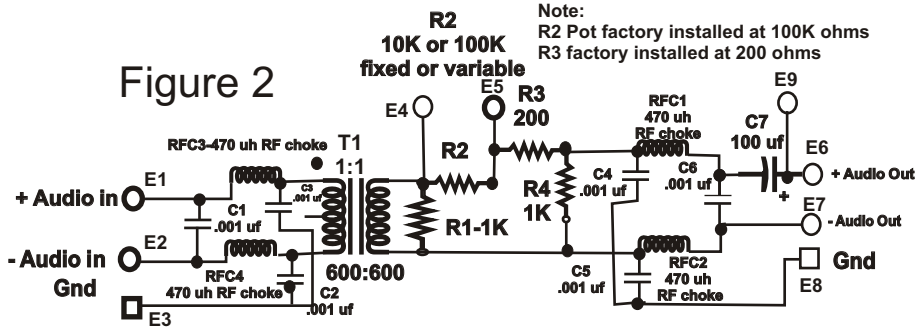
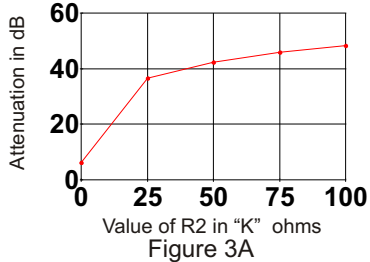
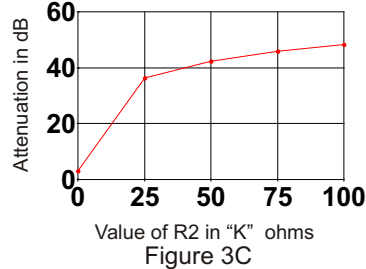

Figure 2

ATTENUATION OF AUDIO INPUT AS R2 CHANGES WHERE R3=200 Ohms



ATTENUATION OF AUDIO INPUT AS R2 CHANGES WHERE R3=0 Ohms



MILLIVOLTS OF AUDIO OUTPUT AS R2 CHANGES WHERE R3=200 Ohms AND 1 VOLT OF AUDIO IS APPLIED TO THE INPUT

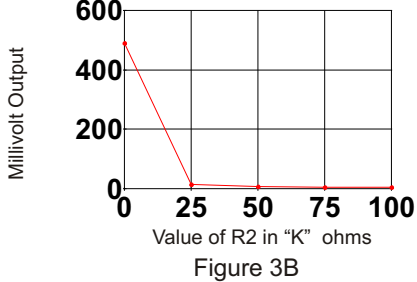

MILLIVOLTS OF AUDIO OUTPUT AS R2 CHANGES WHERE R3=0 Ohms AND 1 VOLT OF AUDIO IS APPLIED TO THE INPUT

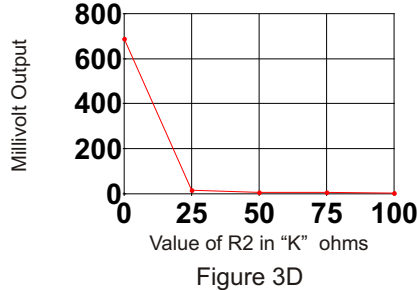

Assumes 600 ohm load on attenuator output						
R1	R2	R3	R4	Attenuation* R2=0 to R2=Max	Impedance to radio R2=0 to R2=Max	Impedance on Xfmr "T1" R2=0 to R2=Max
1000	100000	200	1000	-6.2 to -48.4 dB	336 to 990	384 to 994
1000	100000	0	1000	-3.2 to -48.4 dB	275 to 990	293 to 994

Figure 4

# iBox CONTROLS

## (3) PTT Input (J3)

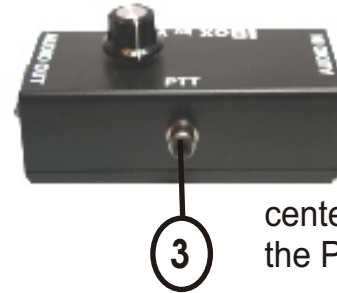

This female RCA connector is used to provide push to talk control (PTT). Grounding the center jack of the connector grounds the PTT line of the Audio Out connector.

## (4) Audio Output (J2)



This 5 pin DIN connector provides attenuated Input audio to the connector. The audio provided is isolated from the input audio. The user may wire cables for either LOW-Z (600 ohms) or HI-Z (50K) balanced or unbalanced. PTT function is also provided at this connector

## Audio Output 5 Pin Male DIN

Din connectors shown on side to be soldered

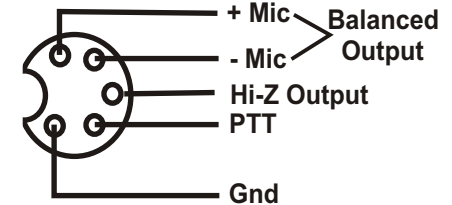

# QUICK START TUTORIAL

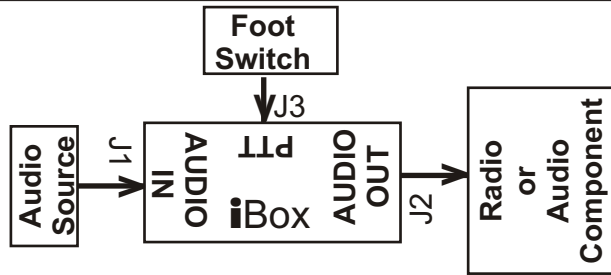

1. Turn the **Output Level Control** fully counter clockwise. (See page 4)
2. Connect the audio source into the **Audio Input** jack (see page 4) using a 1/4" stereo plug. Page 9 shows some possible cable configurations. Make sure the sleeve of the 1/4" stereo plug is connected to the ground of the audio source.
3. Connect the **Audio Output** (see page 5) to what you would like to drive. See pages 10-12 for possible cabling configurations. Make sure that the ground pin on the DIN connector is connected to the ground of what is being driven.
4. If you will be using a foot switch to key a transmitter or other device connect it to the **PTT** RCA connector (see page 5).
5. Prior to applying an audio signal to the input of the **iBox** turn the **Output Level Control** fully counter clockwise. (See page 4).
6. Apply an audio signal to the input of the **iBox**, Turn the **Output Level Control** clockwise until proper audio level for the device being driven is obtained.

## Minimizing the effects of RF

A very common problem many amateur radio operators experience with professional audio equipment while transmitting is audio distortion caused by RF. Techniques have been developed to minimize the effects of RF. In a perfect world one should use a star grounding configuration, using heavy gauge braided wire from grounded equipment to the central ground point and a short run of a heavy gauge wire to a ground rod. In a perfect world all audio equipment should be connected to a high quality power conditioner. In a perfect world all audio cabling should use quality shielded wire (double shielded is best). In a perfect world all audio signals cascading through the audio rack network should be isolated with high quality audio transformers. Few of us live in a perfect world so when we have problems we have to make the RF environment we live in as good as possible.

# iBox SCHEMATIC AND WIRING PICTORIAL

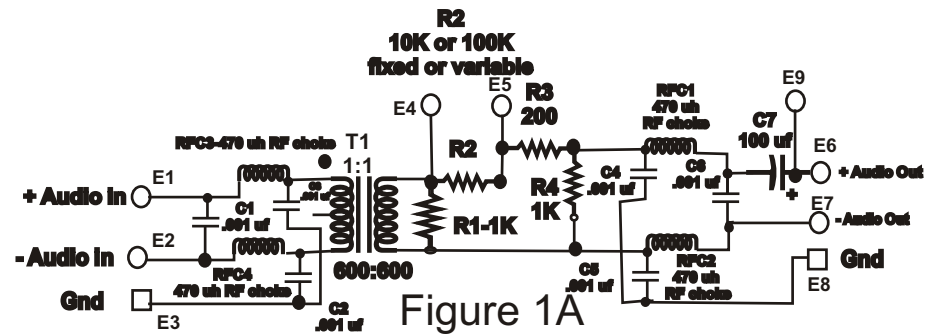

Figure 1A

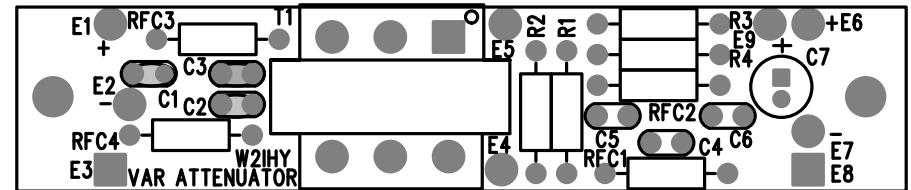

Figure 1B

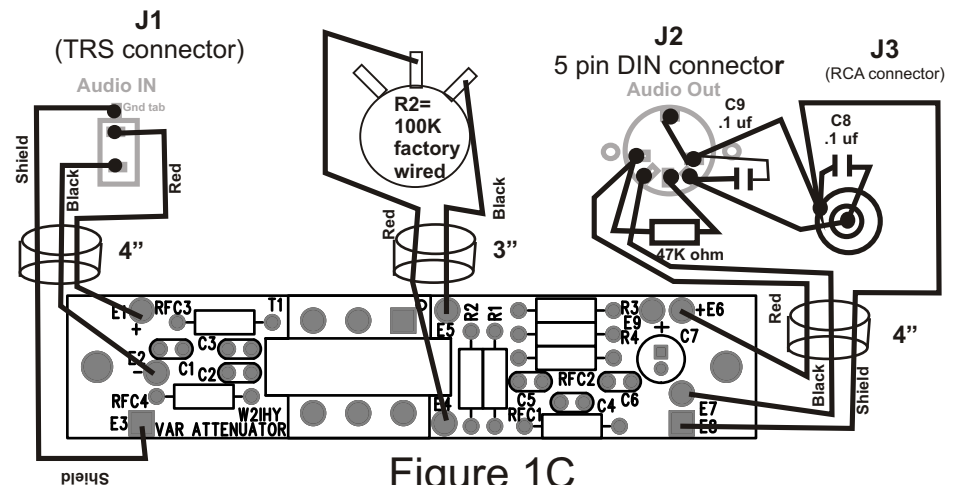

Figure 1C

-----Parts List-----	
C1-C6 - .001 uf mylar	R3 - 200 ohm 1/4 watt 5% resistor
C7 - 100 uf radial electrolytic	R1,R4 - 1K ohm 1/4 watt 5% resistor
C8,C9 - .1 uf monolithic ceramic capacitors	R2 - fixed resistor or variable potentiometer
J1- 1/4" stereo jack	R5- 47K 1/4 watt 5% resistor
J2 - 5 Pin DIN	RFC1 - RFC4 - 470 uh miniature r.f. Choke
J3 RCA panel mounted jack	T1 - 1:1 600 ohm Audio Transformer